

# Alloptic MicroNode™ 200 RFoG ONU



The Alloptic **MicroNode 200 Forward and Return Path RFoG ONU**, specifically designed for international RFoG applications, delivers advanced bi-directional, interactive RF services over a passive fiber optic distribution network. The MicroNode 200 RFoG ONU serves as the optical transport layer for RF video, DAVIC, and DOCSIS technologies in deep fiber and FTTH networks. By extending the optical network directly to a home or building, the MicroNode 200 RFoG ONU eliminates neighborhood HFC nodes. This not only removes the costs of the annual testing and maintenance required to operate the HFC nodes, but also the ongoing power requirements of nodes and RF amplifiers. The MicroNode RFoG ONU provides bi-directional services over extended RF frequencies (up to 1GHz) while being agnostic to both headend and customer premises equipment (CPE), and preserving today's operating processes. The 200 series of MicroNodes provides higher RF output power for higher-loss in-home wiring and multi-subscriber applications, removing the requirement for a distribution amplifier at the customer premise. Alloptic's MicroNode 200 RFoG ONU: flexibility to grow your network to meet customer demand now and in the future.

## Benefits

- Reduces network costs via elimination of HFC nodes
- Allows deployment of fiber optic distribution network while leveraging existing RF and DOCSIS investments
- Universal support for headend and CPE equipment
- High performance, ultra low noise burst mode enables use of full RF spectrum for the return path, resulting in increased available bandwidth
- Enables the low maintenance and high reliability of an all-fiber access network
- Reduced power consumption via green technology

## Features

- Extended spectrum RF video
- Analog & digital video formats
- Universal HFC set top box, cable modem and headend support
- Transparent return path capability (protocol and modulation format agnostic)
- Optical AGC with positive RF up-slope
- Supports in-home applications without amplifiers
- In-home power over 75 Ohm coax cabling
- Ultra low ingress noise performance
- High RF power output, removing requirement of distribution amplifier at the customer premise



Imagine the Possibilities™

# Alloptic MicroNode™ 200 RFoG ONU

## Specifications

### Physical

- 1.2" H x 4.3" W x 6" D  
3.1cm H x 10.9cm W x 15.2cm D
- Weight: 12oz / 0.3kg

### Indicators/External Alarms

- Green LED power indicator
- Red LED loss of signal indicator

### Optical Interface

- 1 recessed SC/APC female fiber connector
- Optical receive power test point

### Customer Interface

- 75 ohm coax "F" connector

### Downstream Characteristics

- Input wavelength: 1540-1565nm
- Input power range: +1 to -6dBm
- Loss of optical power alarm: < -11dBm
- RF Output @ 550MHz: +34dBmV/ch ±1dBmV
- Frequency response:  
MNT0201: 50MHz to 1GHz  
MNT0204: 88MHz to 1GHz
- Flatness: ±1dB
- Up-tilt 50MHz/88MHz to 1GHz: 6dB
- CNR @ -4dBm input power: 48
- CSO @ 0dBm input power: 60
- CTB @ 0dBm input power: 60

### Return Path Characteristics

- Class 1 laser
- Wavelength: 1310 ±50nm
- Output power: +2dBm to +4dBm
- Input dynamic range: +10dBmV to +30dBmV
- Frequency response:  
MNT0201: 5MHz to 42MHz  
MNT0204: 5MHz to 65MHz

### Flexible Installation

- Operate on a single PON fiber architecture
- Installs into many different enclosures
- Temperature-hardened

### Power and Environmental

- Operating temperature: -40°C to +65°C
- Humidity: 5% to 95% non-condensing
- Power input voltage: 10 to 16VDC (12VDC nominal)
- Power consumption: 5 watts max  
4.3 watts typical

## Ordering Information

Part #	Description
MNT0201	MicroNode0201 RFoG ONU (42MHz/1310nm RP)
MNT0204	MicroNode0204 RFoG ONU (65MHz/1310nm RP)

## Power

The following Alloptic power supplies may be used to operate MicroNode 200 RFoG ONUs.

Part #	Description
PSB8000	12VDC, 24W UPS (Charger & 7.2AH battery)
PSB8002	12VDC, 24W UPS hardened (Charger & 7.2AH battery)
PSB1005	12VDC, 24W brick, plug-mounted
PSB1006	12VDC, 24W brick, international plug-mounted
PSB1007	12VDC, brick, plug-mounted, coax feed
PSB1008	12VDC, brick, international plug-mounted, 5mm barrel plug
PSB1009	12VDC, 30W hardened UPS for OSPE202 (240VAC)
PSB1010	12VDC, 30W hardened UPS for OSPE202 (120VAC)
BAT1002	12VDC, 7.2AH battery for OSPE202 and PSB8000 series

## Mounting

The MicroNode RFoG ONUs may be mounted directly on an interior wall or into any of the following Alloptic enclosures.

Part #	Description
OSPE110	Enhanced plastic outside enclosure
OSPE120	Plastic outside enclosure with NID
OSPE202	All-in-One metal outside enclosure

## Standalone RFoG Architecture

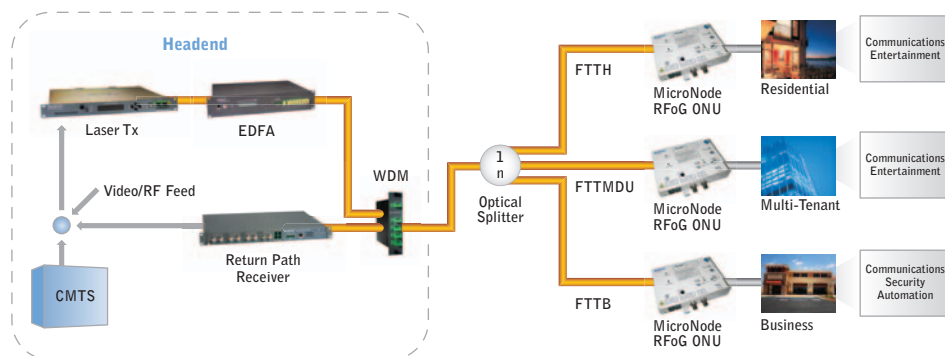

## Standards and Certifications

- UL listed, CE mark certified
- Meets or exceeds FCC part 15b
- IEC 608251:1993+A1:1997+A2:2001
- 2004/108/EC
- EN55022, EN55024, EN50083, EN61000-3 and EN60950
- RoHS
- SCTE 55-1, 55-2
- Compatible with DAVIC & DOCSIS
- SCTE IPS SP910



[www.alloptic.com](http://www.alloptic.com)

Alloptic, Inc.  
2675 Collier Canyon Road  
Livermore, CA 94551  
925.245.7600