

# Alloptic ORCV412 RFoG ONU



The **Alloptic ORCV412 RFoG ONU** delivers downstream RF services over a passive fiber optic distribution network. The ORCV412 serves as the optical transport layer for RF video in deep fiber and FTTH networks. The ORCV412 enables the benefits of a fiber optic distribution network while leveraging existing headend investments for downstream video. The ORCV412 RFoG ONU provides full-spectrum RF frequencies (up to 2.2Ghz) with universal support for headend and customer premises equipment (CPE), and preserves today's operating processes.

## Benefits

- Allows deployment of fiber optic distribution network while leveraging existing investments
- Universal support for headend and CPE equipment
- Enables the low maintenance and high reliability of an all fiber access network
- Reduced power consumption via green technology

## Features

- Extended spectrum RF video
- Analog & digital video formats
- Supports in-home applications without amplifiers
- In-home power



# Alloptic ORCV412 RFoG ONU

## Specifications

### Physical

- 1.2" H x 3.5" W x 5" D  
3.0cm H x 8.9cm W x 12.7cm D

### Indicators/External Alarms

- Green LED power present
- Red LED for loss of optical signal

### Optical Interface

- SC/APC female fiber connector

### Customer Interface

- 75 Ohm Coax "F" connector

### Optical characteristics

- Typical operating range: >20km
- Input dynamic range: 0 to -6dBm
- Input wavelength: 1545–1565nm
- Loss of optical power alarm: -11dBm

### RF characteristics

- RF Output @ 550MHz:  
+16dBmV/ch ±2dBmV
- Freq response: 50MHz-2.2GHz
- Typical load w/o amplification: 4 splits
- CNR @ -6dBm input power: 48
- CSO @ 0dBm input power: 55
- CTB @ 0dBm input power: 60

### Power & Environmental

- Operating temperature range:  
-40°C to +65°C
- Humidity: 95% non-condensing
- Power input voltage: 10 to 16VDC
- Power consumption: 3 Watts

### Standards and certifications

- UL listed, CE mark certified for safety
- Meets or exceeds FCC part 15b for emissions
- RoHS

### Ordering information

Part #	Description
ORCV412	Single fiber Optical Receiver, 3rd lambda, 1port, WB

### Power

The following Alloptic power supply options may be used to operate the optical receiver products. Note: The optical receiver gets its power directly from the Alloptic ONT when it is used in the same enclosure. Separate power is not required in this case.

Part #	Description
PSB8000	12VDC, 24W UPS (Charger & 7.2AH battery)
PSB8002	12VDC, 24W UPS hardened (Charger & 7.2AH battery)
PSB1005	12VDC, 24W brick, plug-mounted
PSB1006	12VDC, 24W brick, international plug-mounted
PSB1009	12VDC, 30W hardened UPS for OSPE202 (240VAC)
PSB1010	12VDC, 30W hardened UPS for OSPE202 (120VAC)
BAT1002	12VDC, 7.2AH battery for OSPE202 and PSB8000 series

### Mounting

The optical receivers may be mounted directly on an interior wall, or into any of the following Alloptic enclosures

Part #	Description
OSPE101	Basic Plastic outside plant enclosure
OSPE110	Enhanced Plastic outside plant enclosure
OSPE202	All-in-One metal enclosure

### Downstream RFoG

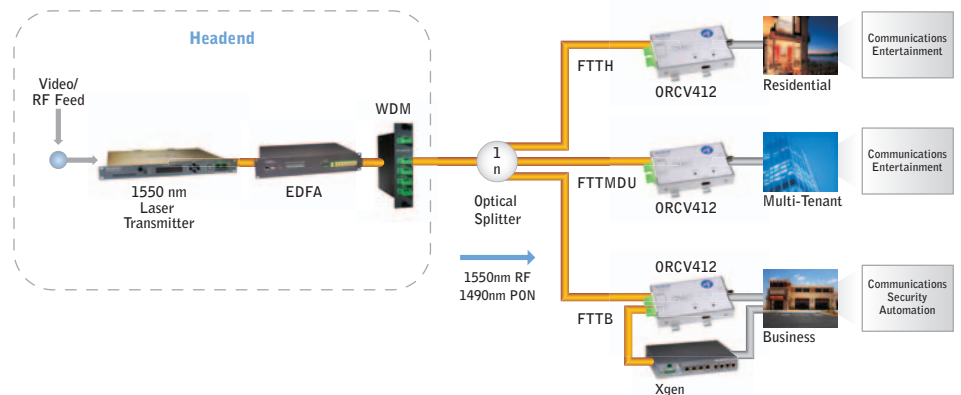

[www.alloptic.com](http://www.alloptic.com)

Alloptic, Inc.  
2675 Collier Canyon Road  
Livermore, CA 94551  
925.245.7600