

Alloptic Return Path Transmitter



Alloptic **Return Path Transmitters** are an integral part of two-way RF access networks, converting return path RF signals into standard optical signals at the remote hubs to enable long distance transmission of combined return path information. Not only do Return Path Transmitters enable long distance transmission, they can also provide a cost effective solution in fiber starved environments, aggregating multiple return paths over a single fiber. The Return Path Transmitters compliment Alloptic's Return Path Receivers, configured with four independent receivers and a single output in a compact 1RU enclosure.

All transmitters are temperature-hardened and support both remote and local management, allowing installation in any network environment including outside plant sites where temperatures are not controlled.

Benefits and Features

- Remote hub aggregation for extended reach of RF return path signals
- Optimize efficiencies of fiber use through aggregation and bundling over single fiber return
- Compact size: 19" rack mounted, 1 RU form factor
- Flexible management: Front-panel & remote SNMP controls
- Temperature-hardened for outside plant environments
- Test/monitor points for each RF input
- Front and rear access options for easy installation in any environment
- -48VDC power, redundant A/B inputs
- Compatible with multiple return path receivers



Imagine the possibilities...

Return Path Transmitter

Specifications

Physical

Dimensions

- 19.0"W x 10"D x 1.72"H
- 48.3cm W x 30.5cm D x 4.4cm H
- 1RU 19" rack mounting

Interfaces

- 1 SC/APC connector for optical output
- 4 F-type connectors for RF inputs
- 1 RJ45 connector for management

Indicators and Alarms

- Power, Port Activity, Port Select
- Attenuator Display

Optical Characteristics

- Wavelength: 1310nm \pm 10nm
- Output Power: +4.5dBm \pm 1.5dB
- Laser Type: CWDM
- Link Length: 40km (dispersion limited)

RF Characteristics

- RF Input Bandwidth: 5Mhz to 100MHz
- RF Input Impedance: 75 ohm
- RF Test Point/Monitor: -20dB+/-0.75dB from input power
- Port to port isolation: 35dB
- Input Return Loss (min): <16dB
- Input Power Range: 10 to 30dBmV

Performance

- NPR/Dynamic Range @ -5dBm into receiver: 40/13dB

Management

- Web-based interface
- SNMP
- GEMS® support

Environmental & Power

- Temperature Range: -40C to +65C
- Humidity: 5%-95% relative humidity, non-condensing
- Power: -48 VDC, dual A/B inputs
- Power consumption: 19W max.

Regulatory

- FCC Part 15, Class B
- UL 60950 3rd Edition
- TUV
- CE Mark
- RoHS

Ordering information

Part #	Description
EVTX1311	Return Path Transmitter 4 in, 1 optical out, 1310nm
EVTX1312	Return Path Transmitter 4 in, 1 optical out, 1310nm, rear access

Power

The following Alloptic power supplies may be used to operate the Return Path Transmitter products. See Alloptic "Power Options" datasheet for additional details.

Part #	Description
PSB1001	-48VDC, 50W UPS (charger & 20AH 12V battery)
PSAC001	-48VDC, 60W brick
PSAC002	-48VDC, 120W rack mounted power supply
PSBRCK1B	-48VDC, 500W, rack-mounted power UPS (battery not included)
PSBRCK10	-48VDC, 500W, rack-mounted power supply
PSBRCK2B	-48VDC, 1000W, power UPS (battery not included)
PSBRCK20	-48VDC, 1000W, rack-mounted power supply

Hub Application, Return Path Focus

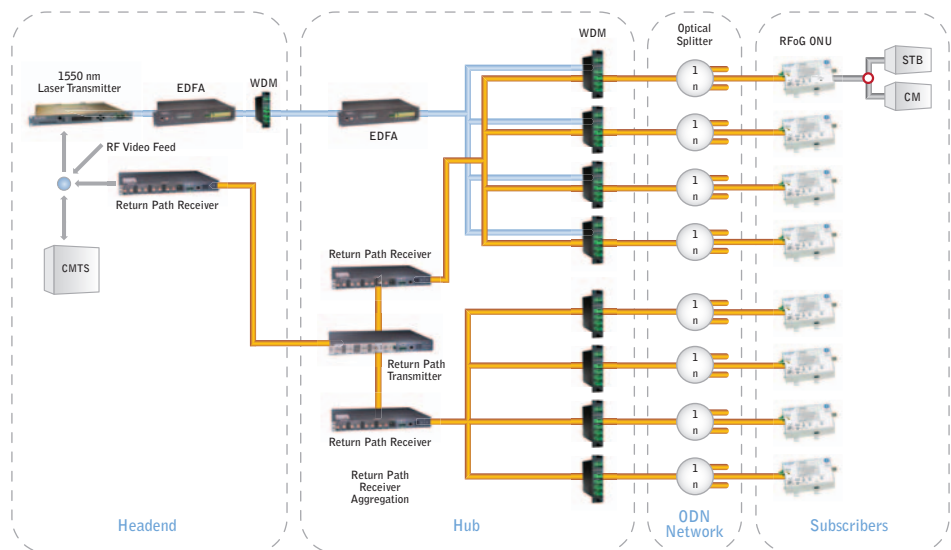

www.alloptic.com

Alloptic, Inc.
2675 Collier Canyon Road
Livermore, CA 94551
925.245.7600