

# Alloptic Xgen9000™ ONT



Meeting the wide variety of communication needs of business and residential applications, the **Xgen9000 ONT** offers voice, video, and data services to businesses and multi-dwelling units with the flexibility of hot-swappable expansion slots. Four expansion slots – up to 16 Ethernet ports, 16 VoIP ports, 24 POTS ports, 20 T1/E1 interfaces or combinations of each – can be provisioned as needed for both customer growth and changes to service offerings. The rugged, temperature-hardened Xgen9000 allows a complete menu of services from a single robust, flexible and cost-effective service platform. QoS and prioritization functionality support business-grade data services and SLAs. The Xgen9000's compact, temperature hardened design and extended-reach Gigabit Ethernet capabilities allow it to deliver high-value services wherever needed.

## Benefits

- Services supported: voice, TDM, data, and RF & IP video
- Hardware efficiency: Multiple services from any Ethernet port
- Advanced data services via symmetrical high speed throughput, bandwidth guarantees, and VLAN service segregation
- Wire speed, full bidirectional data rate on each port
- Support and monitor RF devices such as MicroNode™ RFoG ONUs
- High reliability: temperature hardened and optional PON redundancy
- Subscriber and service provisioning via DPC™ DOCSIS PON controller
- Comprehensive remote management facilitates activation and diagnostics
- Rapid activation via pre-provisioning of the ONT
- Flexible installation: indoor or outdoor mounting, long reach operating range, temperature hardened design
- Standards compliant



# Alloptic Xgen9000™ ONT

## Specifications

### Physical

- 2U rack mount: 3.5" H x 17" W x 11" D  
8.9cm H x 43.2cm W x 27.9cm D
- Weight: 7lbs/3.18kg

### Indicators/External Alarms

- PON & unit status via multi-color LED
- Power input LED
- 30 service port status LEDs
- 2 external alarm inputs
- 2 alarm outputs (major, minor)

### Optical Characteristics

#### PON Interface

- SC/APC optical PHY (single-mode fiber)
- 1.25 Gigabit Ethernet PON
- Maximum operating range:  
70km (loss limited)
- Optional Dual PON support

#### Optional Dual PON capability

- Dual optical transceivers
- Automatic switchover on LOS
- Automatic re-ranging
- Working/protect link status indicators
- Manual lockout and force controls

#### Downstream optics PON (receiver)

- Dynamic range: 0 to -24dBm
- Receive wavelength: 1490nm ±10nm
- Configurable RSSI  
(Receive Signal Strength Indicator)  
range: -15 to -25dBm

#### Return Path PON (transmitter)

- Class 1 laser
- Optical output power level: 1dBm ±1dB
- Optical wavelength: 1310nm ±50nm

### Ethernet Data Ports (Base Unit)

- 1 x 10/100/1000BaseT RJ45 data port
- 1 x 1000BaseFX SFP ports
- Industry standard SFP modules  
(multimode or single-mode)
- Auto speed detect
- Full or half duplex  
(automatic or manual)
- Guaranteed and best effort  
bandwidth controls
- Bandwidth selectivity: Up to 1000Mbps  
symmetrical in 64kbps increments
- 100m reach on CAT5 cable
- >70km reach using SFP optical  
transceiver

### Data switching features

- Port bridging & trunking
- VLAN trunking
- Private LAN service
- IGMP v2 support
- IGMP v2 proxy and snooping with  
"fast leave"
- Diffserv & QoS prioritization
- Transparent LAN services using Q-in-Q

### Port statistics

- Transmit packets/octets
- Receive packets/octets
- Receive errors
- Collisions
- Packet discard reason

### T1/E1 Ports (Base Unit)

#### Physical interfaces

- 4 RJ48 connectors

#### Framing options

- SF (super frame)
- ESF (extended super frame)
- Unframed E1 mode
- CRC E1 mode
- MF E1 mode
- CRC-MF E1 mode
- Basic E1 mode

#### Line coding

- B8ZS
- AMI
- HDB3 E1 line coding

#### Synchronization

- System clocked (synchronous mode)

#### Other

- Loopback diagnostics
- Configurable LBO (line build-out)
- GR824 performance monitoring
- Red/yellow alarm support

### Expansion Modules

#### Physical interfaces

- 4 front accessible expansion slots  
for service modules

### Ethernet Module

#### Interfaces

- 4x 10/100BaseT RJ45 data ports
- Auto speed detect
- Full or half duplex  
(automatic or manual)
- Guaranteed and best effort  
bandwidth controls
- Bandwidth selectivity per port:  
Up to 100Mbps symmetrical in  
64kbps increments
- Each port supports 100Mbps full duplex

### Data switching features

- Port bridging & trunking
- VLAN trunking
- Private LAN service
- IGMP v2 support
- IGMP v2 proxy and snooping with  
"fast leave"
- Diffserv & QoS prioritization
- Transparent LAN services using Q-in-Q

### Port statistics

- Transmit packets/octets
- Receive packets/octets
- Receive errors
- Collisions
- Packet discard reason

### Telephony Modules

#### Interfaces

- 4 RJ11 VoIP connectors
- 6 RJ11 TDM POTS connectors
- VoIP: SIP and MGCP configurable
- VoIP codecs: G.711 and G.729
- A-Law/μ-Law encoding (configurable)

#### Loop characteristics

- Loop voltage: -42 to 56VDC
- Loop current: 20mA (typical)
- Loop impedance: 600/900 ohm loop
- Ringing voltage: 40 to 72 Vrms\*  
Ring capacity: 5 REN/line
- Loop start signaling
- Loop length: 500 feet per GR909
- Receive gain: 0 to -12dB (configurable)
- Transmit gain: -6 to +12dB  
(configurable)

### RF Control Ports for External RF Video

#### Interfaces

- 2 x 10-pin mini connectors
- Auto-switch active port to control  
redundancy
- Compatible with Alloptic MicroNode™  
RFoG ONUs

### T1/E1 Modules

#### Physical interfaces

- 2 or 4 RJ48 connectors

#### Framing options

- SF (super frame)
- ESF (extended super frame)
- Unframed E1 mode
- CRC E1 mode
- MF E1 mode
- CRC-MF E1 mode
- Basic E1 mode

## Line coding

- B8ZS
- AMI
- HDB3 E1 line coding

## Synchronization

- System clocked (synchronous mode)

## Other

- Loopback diagnostics
- Configurable LBO (line build-out)
- GR824 performance monitoring
- Red/yellow alarm support

## Operations

- Remote control
- Alarms with configurable severity
- Optical power threshold alarms
- Software download
- Remote configuration
- TDM line testing & loop back
- Transmission path confirmation testing
- Real time data port statistics
- Auto ONT discovery
- Remote configuration
- DPC™ DOCSIS PON controller support

## Power and Environmental

- Operating temperature: -40°C to 65°C
- Humidity: 5% to 95%, non-condensing
- Dual feed, redundant input power support
- Dual output power headers to support external RF video with redundancy
- Power input voltage: -42 to -57VDC
- Power consumption: 50 watts maximum

## Standards, Certifications, and Patents

- TUV listed, CE mark and FDA certified for safety
- Meets or exceeds FCC part 15a for emissions
- RoHS
- ANSI T1.403, T1.231, T1.408
- ITU-T G.703, G.704, G.706, G.823, G.824
- Telcordia TA5, TR194, TR54016, TR62411
- IEEE 802.3p, 802.3Q, 802.1ad: QinQ, RFC2495, 802.3ah, 802.3U, 802.3ab
- IGMP V2 for IP video support
- MEF 9, 14
- Patents
  - United States (US Pat 7 031 343)
  - Taiwan (#90128223)
  - China (ZL01821736.2)



## Ordering information

Part #	Description
ONUX9140	Xgen9000 base unit with 1 PON, 4xT1, 1Gbps, 4 expansion slots
ONUX9240	Xgen9000 base unit with 2 PON, 4xT1, 1Gbps, 4 expansion slots

## Compatible SFP Transceivers for Xgen 9000

Part #	Description
OPT2100	1000base-X, SFP, 850nm, MM, 200m
OPT2200	1000base-X, SFP, 1310nm, SM, 20km
OPT2300	1000base-X, SFP, 1550nm, SM, 70km

## Expansion modules for Xgen9000

Part #	Description
FSTE001	4 x 10/100BaseT Fast Ethernet card
T1E1002	2 x T1/E1 TDM expansion card
T1E1004	4 x T1/E1 TDM expansion card
POTS006	6 x POTS expansion card, RJ-11
VOIP004	4 x VoIP expansion card, RJ-11

## Compatible power systems

Part #	Description
PSB1001	-48 Volt (UPS Charger and Battery)
PSAC001	-48 Volt (Brick)
PSAC002	-48 volt rack mounted power supply

## EPON Business & MTU Services

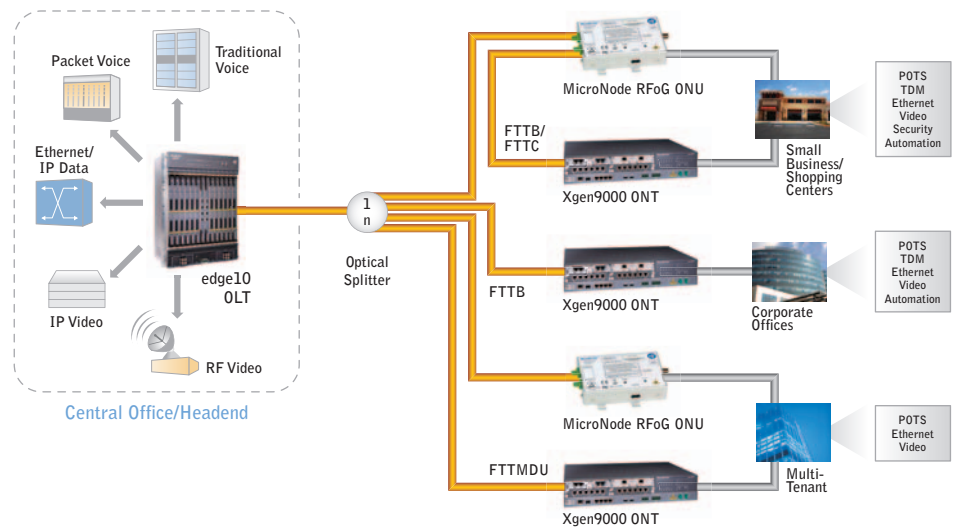



[www.alloptic.com](http://www.alloptic.com)

Alloptic, Inc.  
2675 Collier Canyon Road  
Livermore, CA 94551  
925.245.7600